

Electromagnetic transmitters
Series DSE 22../18..

(old series FTG 291 and FTG 1050)

General

The pulse transmitter serves to convert rotational and linear movement into electrical signals and consists of an iron core with induction coil followed by a permanent magnet. The pole wheel, which rotates in front of the transmitter head, influences the magnetic field so that, according to the law of induction, a voltage is produced in the coil proportional to the rate of change of the magnetic flux in the iron core. The magnitude of the transmitter voltage is dependent upon the distance between the pole wheel and the transmitter and upon the pole dimensions. Moreover, it is initially proportional to the rotational speed of the pole wheel and therefore proportional to the rotational speed of the measurement shaft. The electromagnetic transmitter does not require auxiliary power to produce a signal.

Technical data

Type	Transmitter voltage U_n (Vpp) (1)	Standard pole wheel module	Permissible range	Factor K_n	Relationship $Dk = f(d)$	Applicable curve Diag.A	Diag.B	Coil resistance R_i (ohms)	Inductivity L_i (mH)	Core \varnothing (mm)
FTG291	45	2	1...4	0.85	$Dk = d$	1	1.2.3	900	310	2.7
DSE2210.T.	38	2	1...4	1.0	$Dk = d$	1	1.2.3	900	360	2.7
DSE2210.H.	21	2	1...4	1.0	$Dk=d+0.3$	1	1.2.3	900	360	2.7
FTG1052	58	4	2...8	1.0	$Dk = d$	2	4.5	800	350	5.0
FTG1052.H	34	4	2...8	1.0	$Dk=d+0.3$	2	4.5	800	350	5.0

(1) Measured with a pole wheel circumference speed of 5 meters per second.
Standard module as well as pole wheel to transmitter distance d of 0.1 mm.

Lowest discernible rotational speed

The graph and columns 4 to 7 in the technical data table serve to simplify the determination of the parameters for the pole wheel to be selected (module, diameter), of the pole wheel-transmitter distance d and they also serve to verify the suitability of a configuration chosen for a particular application.

suitable for
physical measurements
linear speed
rotational speed
 ≥ 10 rpm.

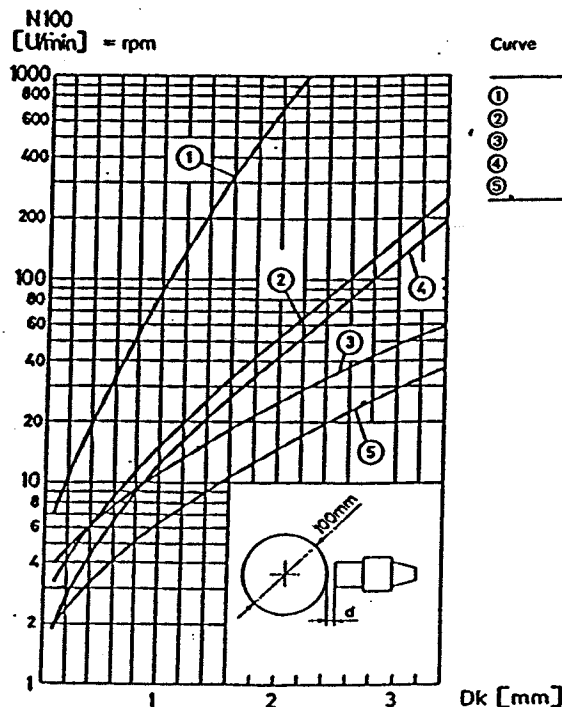
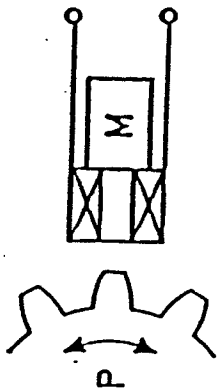

Curve	Pole wheel module	Transmitter type
①	1	FTG 291, 1055, DSE2210
②	2	do.
③	4	do.
④	2	FTG 1052, 1056
⑤	4	do.

IN CHARGE OF SPEED

In the graph, the minimum detectable rotational speed N100 in relation to the pole wheel-core distance DK can be read off for various listed combinations of pole wheel modules and transmitter types. This gives a basic response sensitivity of sequential electronics of 50 mVeff. The curves are applicable for a pole wheel diameter of 100 mm and represent the positions of the constant transmitter voltage at the level of 50 mVeff corresponding to 140 mVss. To ascertain the minimum measurable rotational speed N100 at a given pole wheel-core distance DK, the N100 values found in the graph should be multiplied by the factor kn shown in column 4 in the table. The general formula for determining the response rotational speed n/min. for given values, for the pole-wheel diameter dp (m) and the pole wheel-core distance DK is as follows:

$$N_{min}(DK) = N100(DK) \times K_n \times \frac{0.1}{D_p}$$

To determine the n/min. at a given pole wheel-transmitter distance d, the relationship $DK = f(d)$, determined by the transmitter type, as per column 5 of the table should be taken into consideration.

Installation

The transmitter is mounted with its middle point over the pole centre. The transmitter is normally fixed over the centre of the wheel when using toothed or grooved pole wheels or with radial transmitter installation. A certain amount of axial shift of the pole wheel is then permissible depending upon the wheel width. However, the centre of the transmitter must be at least 3 mm from the wheel in all operating conditions.

It is important that the transmitter should be firmly mounted and free from vibration. Transmitter vibrations opposite the pole wheel induce additional voltage pulses. The transmitters are not sensitive to oil, lubricants etc. and may be operated in messy premises. When installing the transmitter, the smallest possible pole wheel-transmitter distance should be set. However, this distance must be set so that the transmitter does not touch the pole wheel under any circumstances.

The transmitter-pole wheel distance does not affect the calibration of the whole plant.

Connections

The transmitter leads are sensitive to cross-talk from interfering voltage. The following 2 points should be noted for this reason:

- at all times a screened, two-wire cable should be used for the transmitter lead. The cable screening should be earthed to the connected instruments by means of the terminals provided for this purpose.
- the transmitter leads should be situated as far away as possible from large electrical machines. Under no circumstances should they be laid parallel to mains power cables.

The maximum permissible length of the transmitter lead depends upon the transmitter voltage, the cable layout and upon the cable capacity and inductivity per unit length. However, it is generally advantageous to keep the distance between transmitter and connected evaluating instruments as short as possible. The transmitter cables may be extended by inserting a connection box with an IP20 connector (in accordance with DIN 40050). We recommend the JAQUET cable type S2 as extension cable.

Testing an electromagnetic transmitter

It is possible to test the transmitter and its feed cables by taking the following measurements:

- measurement of the true resistance between the two active connections. Standard values are given in the type designation list. This test facilitates the discovery of breakdowns in the transmitter or its feed cables.
- measurement of the insulation resistance between the two active connections of the screening and the housing. The insulation resistance must total at least 100 MOhm.

Type	Housing thread	Material	Protection Head	Protection Connection	Temperature range °C	Connector type (supplied)	Cable type	Cable length m	Weight g
FTG 291	M18x1.5	Alu	IP64	IP64	-25...+85	-	S2	1.5	135
FTG 291 A	M18x1.5	Alu	IP64	IP50	-25...+85	80-MC 2 M	without	-	65
DSE2210ATZ	M22x1	stainless steel	IP64	IP50	-25...+85	MS3106A-10SL-3S	without	-	200
DSE2210STZ	M22x1	stainless steel	IP64	IP64	-25...+85	-	S2	5	580
DSE2210MTZ	M22x1	stainless steel	IP64	IP64	-25...+85	-	SM2	5	1400
DSE2210AHZ	M22x1	stainless steel	IP68	IP50	-40...+125	MS3106A-10SL-3S	without	-	200
DSE2210SHZ	M22x1	stainless steel	IP68	IP64	-55...+150	-	SH2	2	520
FTG1052A	M22x1	stainless steel	IP64	IP50	20...+85	MS3106A-10SL-3S	without	-	200
FTG1052S	M22x1	stainless steel	IP64	IP64	20...+85	-	S2	5	580
FTG1052SM	M22x1	stainless steel	IP64	IP64	20...+85	-	SM2	5	1400
FTG1052AM	M22x1	stainless steel	IP68	IP50	40...+125	MS3106A-10SL-3S	without	-	200
FTG1052SH	M22x1	stainless steel	IP68	IP64	55...+150	-	SH2	2	520

Connection diagram

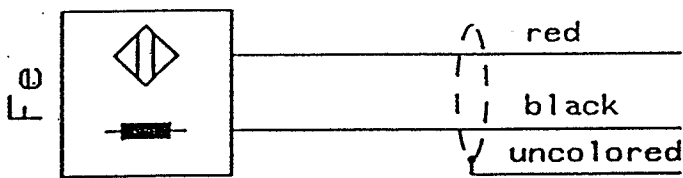

Types

- FTG 291
- DSE 2210 STZ
- DSE 2210 MTZ
- DSE 2210 SHZ
- ~~FTG 1052 S~~
- ~~FTG 1052 SM~~
- ~~FTG 1052 SH~~

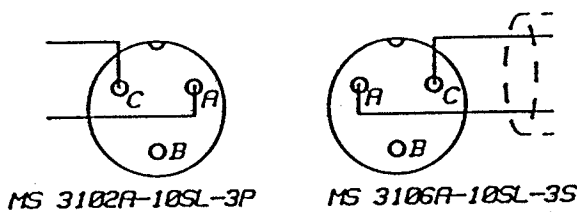

- DSE 2210 ATZ
 - DSE 2210 AHZ
 - ~~FTG 1052 A~~
 - ~~FTG 1052 AH~~
- Plug
MS3106A-10SL-3S
(supplied)

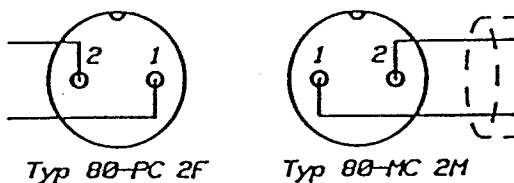

- FTG 291 A
- Plug
80-MC 2M
(supplied)

Massbilder / Dimensions

Typen

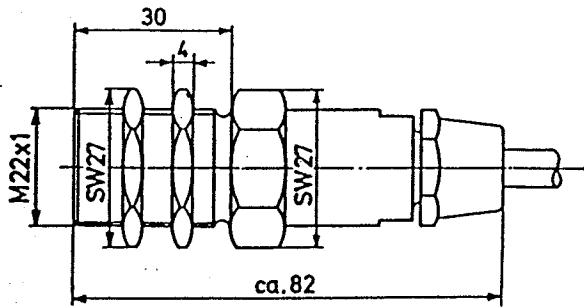

DSE 2210 STZ
DSE 2210 SHZ
~~FTG 1052 S~~
~~FTG 1052 SH~~

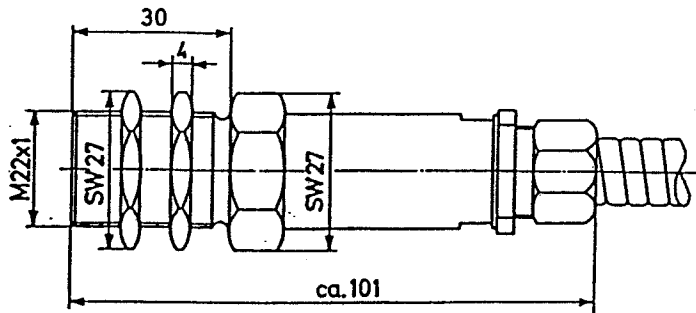

DSE 2210 MTZ
~~FTG 1052 SM~~

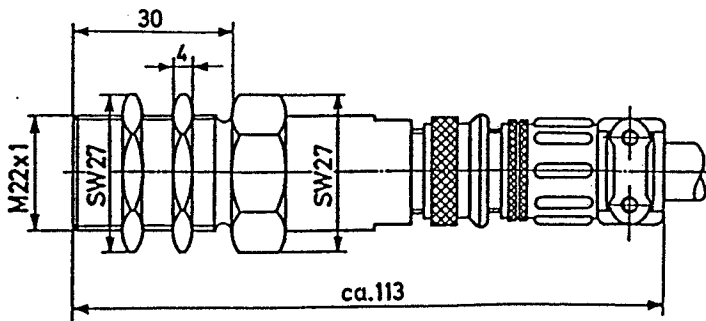

DSE 2210 ATZ
DSE 2210 AHZ
~~FTG 1052 A~~
~~FTG 1052 AH~~

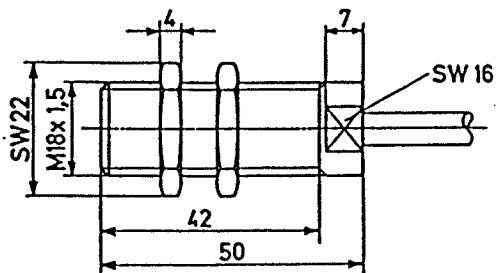

FTG 291

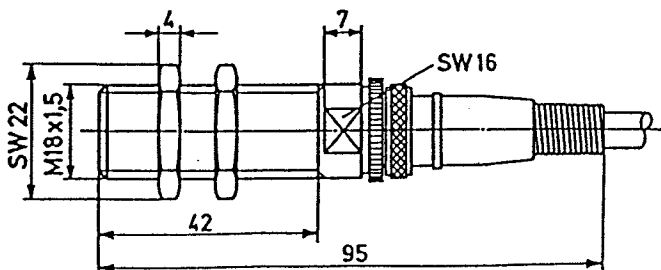

FTG 291 A